

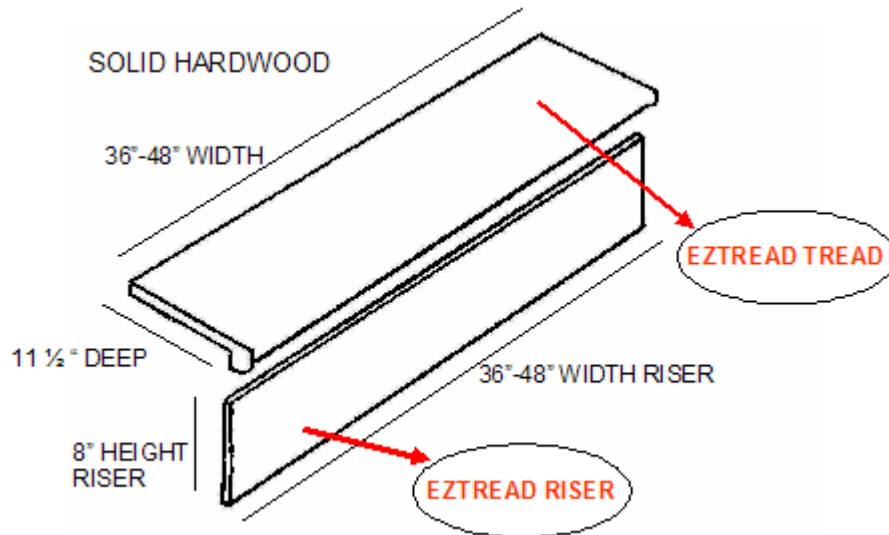

34 Blevins Drive, Suite 1
New Castle, Delaware 19720
Telephone: (302) 328-9444
Facsimile: (302) 328-9445
information@eztread.com
www.eztread.com

INSTALLATION INSTRUCTIONS FOR EZTREAD STAIRCASE REFACING SYSTEM®



BEFORE STARTING:

- Read through all instructions before installing the EZTREAD STAIRCASE REFACING SYSTEM®.
- Verify that the EZTREAD STAIRCASE REFACING SYSTEM® meets local and/or regional codes before installation.
- The existing steps must be clean, flat, structurally sound, securely nailed, and free of foreign matter and projections.
- Pre-fabricated staircases may require the removal of, or building out, the existing stair nose. The removal of the stair nose may require cutting with a power circular saw, sawsall, jigsaw, and /or hand saw. Be careful not to damage or mar existing stringers.
- For new construction please discuss stair requirements with builders/contractors to save time and preparation.



CAUTION: WOOD DUST

Sawing, sanding and machining wood products can produce wood dust. Airborne wood dust can cause respiratory, eye and skin irritation. The International Agency for Research on Cancer (IARC) has classified wood dust as a nasal carcinogen in humans.

Precautionary Measures: If power tools are used, they should be equipped with a dust collector. If high dust levels are encountered, use an appropriate NIOSH-designated dust mask. Avoid dust contact with eyes and skin.

First Aid Measures in Case of Irritation: In case of irritation, flush eyes or skin with water for at least 15 minutes.

If you have any technical or installation questions,
please call EZTREAD at 302-328-9444

CUTTING THE TREADS:

- The EZTREAD installation may start from the top or the bottom of the stairs. Regardless of which starting point is used, dry fit all treads and risers **PRIOR** to adhering to the steps.
- When at the top of stairs, remember to scribe the riser first, before installing the EZTREAD. Use felt paper, scribing paper or a template system such as the stair wizard to make a pattern for each tread and riser. This will reduce the number of times the treads and risers are dry fitted.
- Place the pattern or template on the EZTREAD. Use the template to transfer scribe marks to the tread. Be sure to allow for the riser and stair nose thickness.
- Using the sliding compound miter saw, rough cut the EZTREAD stair tread 1/16" greater than the desired mark. Cut the EZTREAD stair treads to size with a sliding compound miter saw and sharp saw blade. Be sure to cut so that the saw blade teeth cut into the decorative surface.

INSTALLING THE RISERS:

1. Starting at the Top of the Stairs:

- Stair risers should be scribed before the upper tread is glued into position. This edge is then set behind the top of the lower tread. Risers should slip behind the stair nose and support the upper tread, holding the lower tread in place. Risers should be glued with construction grade mastic.
- Using a sliding compound miter saw, rough cut 1/16" greater than the desired mark.
- Cut the tread width to size with a sliding compound miter saw and a sharp saw blade. Be sure to cut so that the saw blade cuts into the decorative surface.

- The final cut of each tread and riser should be cut at least 1/16” shorter than the width of the actual step. This should allow for ease of installation without damaging or marring the stringer, as well as allowing for expansion and contraction.
- Splitting the difference will leave 1/32” gap that should be filled with a color matched caulk after the gluing process is complete.
- Continue the installation from top to bottom. This will help keep traffic off the stair installation.

2. Starting at the bottom of the stairs:

- Scribe the first riser, then use the scribing paper, felt paper or stair wizard to pattern the treads. Rough cut and rout treads and risers as described previously until the stairs are complete.

3. Adhering the Treads and Risers:

- Use construction grade mastic such as **PL Polyurethane Construction Adhesive or Liquid Nails LN-602** to glue the treads and risers.
- Full spread or the bead method is acceptable. For a full spread, use a 3/32” v-notch or square-notch or similar trowel. For the bead method, apply 5 ½” continuous bead (5 beads each being ½” long) of adhesive along the width (long dimension) of the treads and risers.
- No matter which method used, apply a continuous bead of adhesive behind the stair nose in the inside corner, so the riser can seat and fill voids. This will strengthen the stair nose.
- Brad nailing or placing hot melt glue in a few spots will help the EZTREAD stay in place until the construction adhesive has set. **Note: If you choose to nail the risers, be sure to pre-drill.**
- SEE SKETCHES BELOW

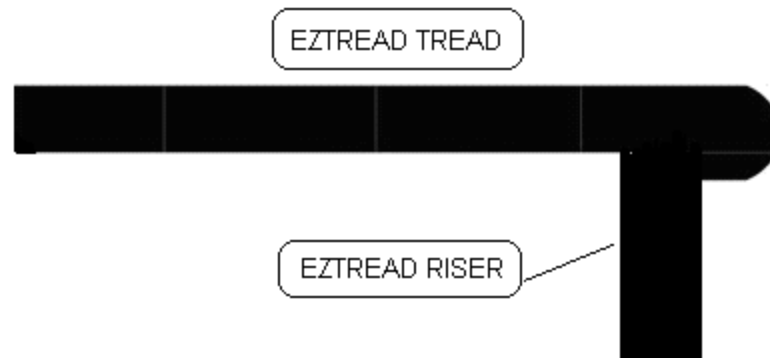



EXTRA ADHESIVE WHERE THE
TREAD AND RISER MEET



REMOVE AT TIME
OF INSTALLATION